

**RELEASE**

**DATE:**

**COMPANY:**

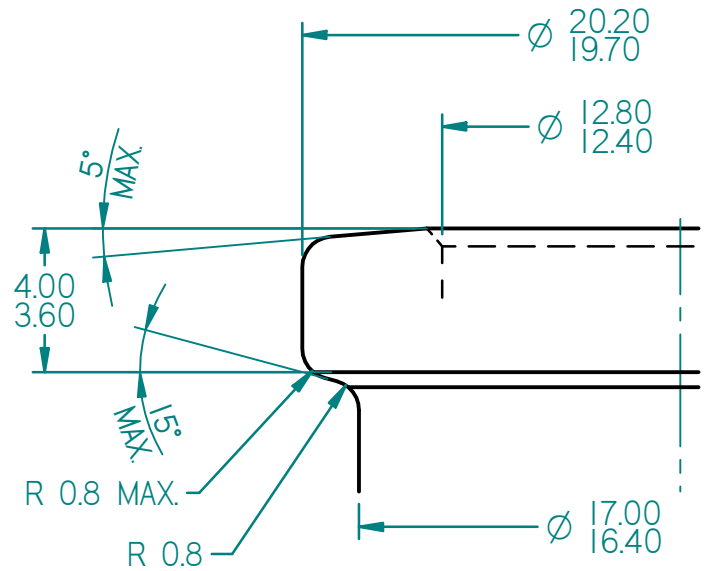
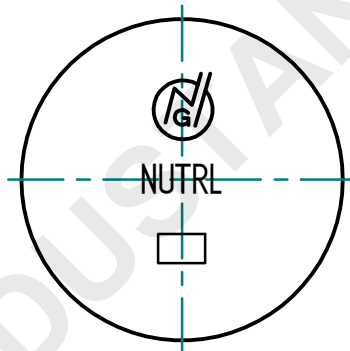
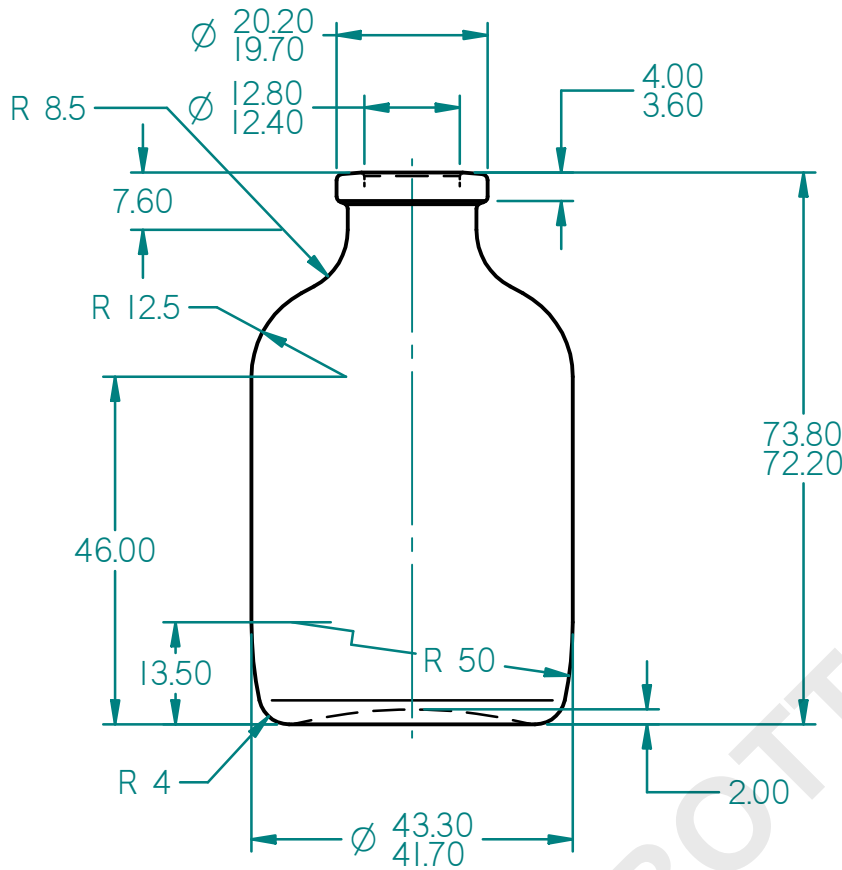

FINISH - 20 mm EURO.

Protective note ISO 16016 observed

<b>GENERAL TOLERANCES</b> <b>DIN 6129-1</b> (DIMENSIONS WITHOUT TOLERANCES ARE FOR REFERENCE ONLY)				FINISH: 20 mm EURO.		O'FLOW CAPACITY: 58.20 - 61.80 ml		ARTICLE NO.:			
				FINISH DWG: NA		WEIGHT: 50 g Approx		5154071100			
				FINISH MOLD NO: 916		TYPE OF GLASS: I COLOUR: FLINT					
				DATE		NAME		<b>TITLE:</b> <h1 style="text-align: center;">50 ml ASTRA</h1>			
				DRAWN 21/11/2013		Paresh					
				CHECKED 21/11/2013		H.B.P.					
				SCALE 1 : 1, 5 : 1							
				 NEUTRAL GLASS & ALLIED INDS. PVT. LTD. MUMBAI / KOSAMBA		MOLD NO.: 066		DRAWING NO.: B 4071		REVISION: 0	
								SHEET: 1 OF 1		FORMAT: A4	
REV. CHANGE DATE NAME				FILE: 50 ml ASTRA.dft							